

28LM Butt Fusion System

Operator's Manual

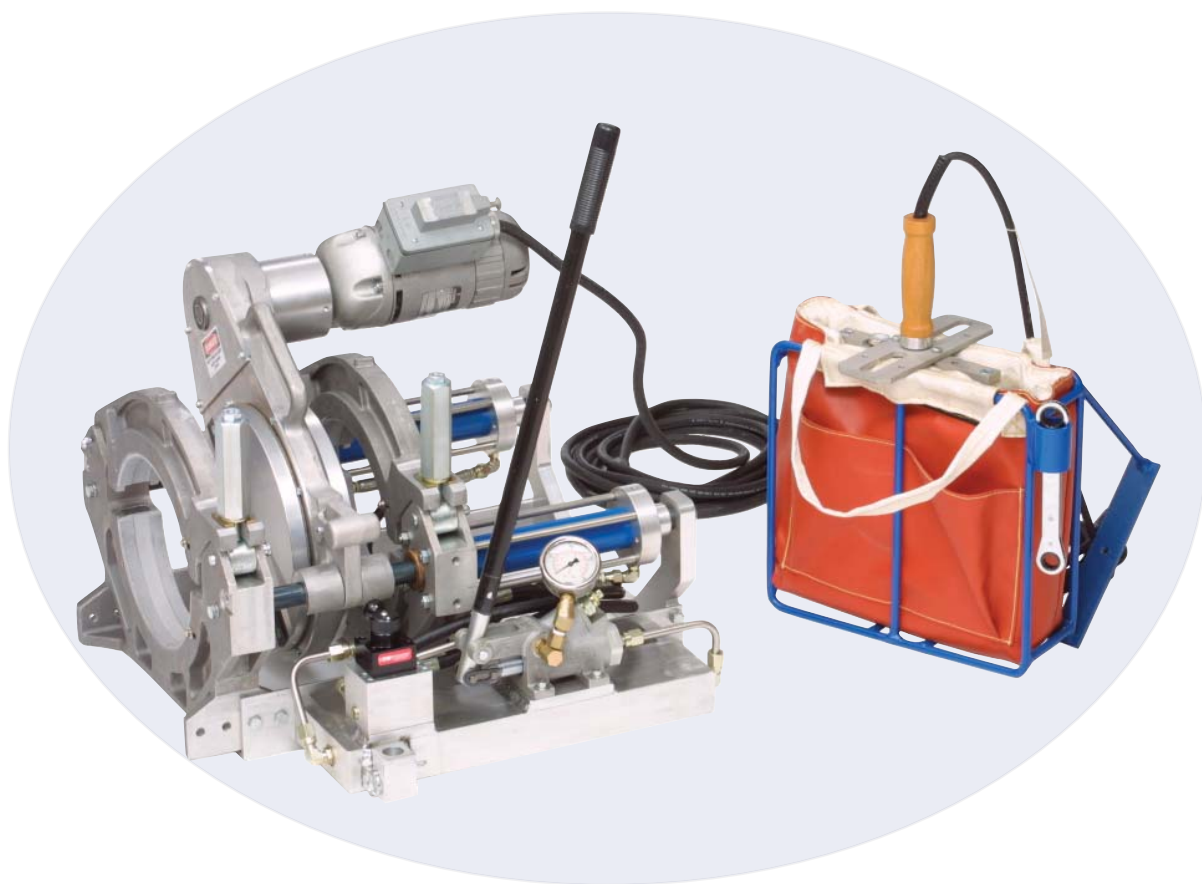

CONNECTRA[®]
simply fusion

Toll Free: 877.776.7100 Tel: 940.612.7100 Fax: 940.612.7105 Web Site: www.connectrafusion.com

Address: PO Box 1319 4400 West Hwy 82 Gainesville, Texas 76241.1319 USA

© Connectra Fusion Technologies, LLC – Revised 4/2005

Table of Contents

Description	3	<i>Facer Assembly</i>	12
Features	3	<i>Heater Assembly</i>	12
Specifications	4	<i>Dissassembly of Hydraulic Cylinder</i>	12
Safety Precautions	5	<i>Routine Maintenance</i>	13
<i>Warnings & Cautions</i>	5	Replacement/Acc. Parts List	14
<i>Electrical Safety Precautions</i>	5	Fusion Pressure Charts	15
<i>Machine Operation Safety</i>	5	Statement of Warranty	19
Operating Procedures	6	Notes	20
<i>Preparation</i>	6		
<i>Load Pipe or Fittings</i>	7		
<i>Facing the Pipe</i>	7		
<i>Pipe/Fitting Alignment</i>	8		
<i>Fusing the Pipe</i>	9		
<i>Removing Pipe</i>	11		
<i>Fusing of Valves/Elbows</i>	11		
Maintenance	11		
<i>Guide Rods</i>	11		
<i>Hydraulic System</i>	11		

<i>Copy information listed on your Warranty Card for your records:</i>	
<i>Model No.</i>	_____
<i>Serial No.</i>	_____
<i>Date Received</i>	_____
<i>Distributor</i>	_____

Description

The purpose of this manual is to provide operating and maintenance instructions for the 28LM Butt Fusion System. The 28LM Butt Fusion System fuses polyethylene pipe quickly and accurately.

An electric motor drives the facing tool, which performs fast, square, butt joint facing, and lifts out of the joining area of the jig.

Two hold down clamps precisely position the pipe. One clamp is stationary, and one clamp moves. These clamps can position straight pipe lengths as well as tees, elbows, stub ends and other fittings.

A heating plate with adjustable thermostatic control heats pipe ends to a molten state. Its non-stick coating prevents contamination of the heater plates and fusion joints. The heater comes with an insulated carrying bag and frame.

A manually operated hydraulic pump provides proper control of the facing and fusion operations.

The maximum system pressure design for this machine is 1500 psi, providing a total of 2946 pounds of actual force at the carriage end. **Please note that “drag factor,” the pressure required to initially move two pieces of pipe, can significantly increase the pressure required for effective fusion. “Drag factor” can be greatly reduced by the use of good pipe rollers/stands and by limiting the lengths of pipe pulled in the fusion process.**



Features

- * Two-clamp unit design allows easy, in-the-ditch access.
- * Ball bearing facer is powered by durable electric motor.
- * Pressure gauge offers excellent control of fusion pressure.
- * Simple controls allows quick training and easy operation.
- * Ported for DataConnect or other competitive data recorders.
- * Rugged design with no “bells and whistles” means less maintenance expense.
- * A superior piece of equipment at an extraordinary price.
- * Limited three-year warranty.



Specifications

Carriage Unit Dimensions

Length	24.00 inches	610 mm
Width	24.00 inches	610 mm
Height	17.00 inches	432 mm
Weight	185 pounds	83.9 kg

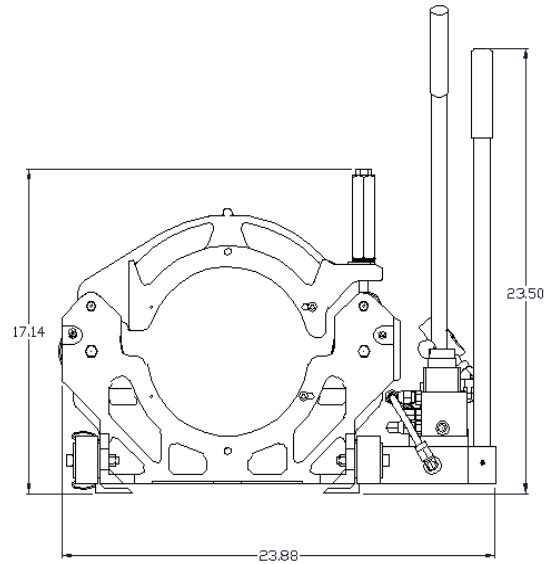

Capacities

Model 28LM - 2" IPS thru 8" DIPS*

Model 28LM-225mm - 63m++m thru 225 mm*

Electrical data

120 VAC Single Phase	Watts	Amps
Facer Motor	1,200	10.0
Heater	2,000	16.6
Total Power Consumption	3,200	26.6

240 VAC Single Phase	Watts	Amps
Facer Motor	1,152	4.8
Heater	2,000	8.3
Total Power Consumption	3,152	13.1

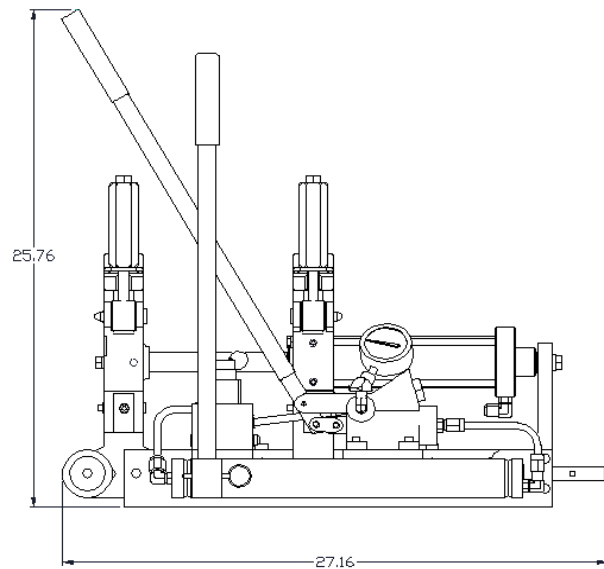

* With the use of optional reducing liners.

Specifications are subject to change without notice.

Safety Precautions

Read this manual carefully before attempting to operate this machine. Working with extreme temperatures and sharp facer blades can be dangerous if proper procedures are not followed. Know proper fusion techniques. Recommendations of pipe manufacturers regarding fusion temperatures, pressure, and techniques must be known to ensure proper fusion joints.

Only responsible, qualified, trained personnel should operate this equipment. Operating personnel should be familiar with the equipment, its functions, its potential hazards and proper precautionary measures.

To prevent tip-over, the fusion machine must be in a stable position. The equipment operator should be aware that potentially dangerous lateral and horizontal forces could exist within a length of pipe and should take precautions to guard against these forces.

Do not wear loose clothing, jewelry, or long loose hair near operating machinery. Recommended safety apparel includes gloves, safety glasses, safety shoes, and hat or hair net.



Warnings and Cautions

The purpose of **Warnings** and **Cautions** in this manual is to call the operator's attention to the possible danger of injury to personnel and damage to equipment. The hazard alert sign above appears in this manual. When you see this sign, carefully read what it says. **YOUR SAFETY IS AT STAKE.**

Warning: Indicates a potentially hazardous situation which, if not avoided, could result in death or serious injury and/or damage to equipment.

Caution: Indicates a potentially hazardous situation which, if not avoided, may result in personal injury and damage to equipment. It may also be used to alert against unsafe practices.



Electrical Safety Precautions

Use power cords sized for the required amperage. Maintain power cords in good condition. Repair or replace worn or broken cords and connectors. The power system is a three-wire grounded system electricity. The electrical power source must be grounded to ensure personnel safety. Take appropriate precautions in wet or damp conditions. Protect wiring from hot surfaces and moving parts.

Machine Operation Safety

Heating plate temperature reaches 450°F. (232°C.). Use caution when handling the plate to avoid burns. Gloves are recommended. Do not lift or pull the heating plate by its power cord. This heater is not explosion proof. Use ground fault devices with this (and all) electrical equipment.



 **Caution: Facer blades are extremely sharp.**

Keep away from facing tool blades while equipment is in operation and during positioning and retracting the facing tool. This motor is not explosion proof. Use ground fault devices with this (and all) electrical equipment.



Note: Machine should be covered when used in inclement weather.

Do not force machine. It will work better if operated within design limits. Apply only slight pressure when facing. Excessive pressure will damage facer motor and drive chain. Maintain machine in top condition.

Use sharp facer blades and keep machine clean for best and safest performance. Follow lubrication instructions contained in this manual.

Operating Procedures

Preparation

Connect the heating plate and the electric facer motor to a proper power source: This equipment is designed to operate on **ALTERNATING CURRENT ONLY!** Operation on any other current will damage

the heater and void the warranty.

Connect heater to AC power source. Temperature was set at factory to 450°F. Permit sufficient heating time to stabilize temperature reading on heater thermometer.

 **Caution: Use on AC power source only. If used on direct current (DC) power, the thermostat in the heater tool will be damaged.**

Proper heating temperature is important in making a good fusion joint. The thermometer built into the heater tool indicates internal temperature and should be used only for reference. To assure the pipe manufacturer's temperature specifications are met, it is recommended that the surface temperature of the heater be measured prior to initial use and at reasonable intervals thereafter.

A hand-held surface pyrometer, Connectra[®] part number 28-8554-1200-10, can be used for measuring this temperature. Several areas should be checked to ensure even heat distribution.

 **Warning: DISCONNECT electrical power BEFORE adjusting heater temperature. If not, the thermostat could be shorted out, resulting in severe electrical shock. Heater is not explosion proof.**



Use the pyrometer to check temperature in the center and at several points around the edges. (Do not use temperature crayons.) Each reading should be +/- 10° of each other.

Temperature adjustments can be made by inserting a flat blade screwdriver into the thermostat

adjusting screw. Turning clockwise will lower temperature and counterclockwise will raise temperature. One complete revolution will adjust temperature about 100°F. Do not turn the screw more than a ¼ revolution at a time, letting heater come to the new temperature before additional adjustments.

 **Caution: Do not adjust heater above 550°F. This may result in damage to heater components and cause deterioration of non-stick surface coating on face of the heater, which can result in contaminated fusion joints.**

For butt-fusion of 8-inch DIPS pipe and/or fittings, no liners are required. For fusion of smaller pipes and/or fittings, reduce liner size accordingly.

To calculate proper gauge pressure, use the following formula:

Where

OD = Outside diameter (actual pipe diameter)

ID = Inside diameter

SDR = Standard dimensional ratio

WT = Wall thickness

IP = Interfacial Pressure (use pipe manufacturer's recommendation)

PA = Combined effective piston area (in²) for both cylinders

PA for the 28 HP is 1.964 (in²).

*Drag Factor = Hydraulic fusion pressure required to move the carriage holding the pipe. 30 psi is generally accepted as a minimum.

To find wall thickness:

$$WT = \frac{OD}{SDR}$$

To find ID:

$$ID = OD - (WT \times 2)$$

To find carriage hydraulic gauge pressure (psi):

$$\text{Hydraulic Gauge Pressure} = \frac{(OD^2 - ID^2) \times .7854 \times IP + \text{Drag Factor}}{PA}$$

* The drag factor is an important parameter easily overlooked. If two long pieces of pipe are being fused the drag factor can easily reach several hundred psi.

Note: This data is provided as a guide only and is believed to be accurate and reliable. However, the user should always use the recommendations and procedures of the pipe manufacturer and/or the owner of the pipeline. Due to the variability of applications and service conditions, no warranty or guarantee, expressed or implied, is given in conjunctions with the use of this data.

Check the fluid level daily. Add fluid when necessary. (See the MAINTENANCE section of this manual.)

Load Pipe or Fittings

Set the hydraulic directional valve to the right (open) position and operate the pump. Operation of the pump will separate the clamps (open the carriage).

Unlock the facing tool by lifting the catch at the lower front of the facing tool. Lift the facing tool out of the fusion jig.

Open all of the hold-down clamps.

Place two lengths of pipe into the fusion jig so that each end protrudes about two inches (5 cm) past

the inside hold-down clamps. Load the shorter pipe section in the moveable clamp (carriage) so that, during joining, the hydraulic system moves the shorter pipe section.



Place the other two pipe ends on suitable pipe supports and adjust to the level of the hold-down clamps. Close the hold-down clamps.

Facing the Pipe

Clean the pipe ends, making sure they are free of foreign material. Inspect facer blades for sharpness. Replace if necessary.



Caution: Make sure power to the facer motor is disconnected before replacing blades.

When replacing blades, make sure facer plates are free of dirt and foreign material so that the blades will seat properly.



Caution: Facer blades are extremely sharp. Handle with care when replacing.

Place the facing tool into place between the pipe ends. Lock the facing tool in place.

Connect the facing tool to a proper power source and start the drive motor.

Set the hydraulic directional valve in the left

(closed) position and operate the pump. Feed the pipe to the facing tool, using care not to labor or stall the facing tool.

Face the pipe ends until a long curl of plastic shaving is visible completely around both pipe ends.



Caution: Apply only slight pressure when facing. Excess pressure can cause damage to the facer and motor.

Continue to maintain slight pressure on facer until the facer stops are in contact with both clamps and until motor speeds up to normal speed and runs free. This indicates that the clamp assemblies have contacted the facer stops and facing has been completed.



Turn facer motor switch to the "off" position and allow blades to come to a complete stop

Set the hydraulic directional valve to the right (open) position, and operate the pump until the carriage is in its full open position.

Remove the facing tool.

Pipe/Fitting Alignment

Remove all shavings and inspect the pipe ends to see that they are completely faced. Bring the pipe ends together, and verify that alignment and

squareness meet the pipe manufacturer's recommendations.

Note: Do not touch faced surface of the pipe or fittings. These surfaces must be kept free of dirt, water, body oil and other contaminants, which may cause defects in the fusion.

If necessary, repeat the facing operation and/or adjust the pipe in the fusion jig until alignment meets the pipe manufacturer's recommendations.

Check pipe alignment by closing the clamps to bring the pipe ends together. Carefully check pipe alignment and the fit of the faced surfaces. This can be done by running a straight edge across the seam to determine if one edge is raised above the other.

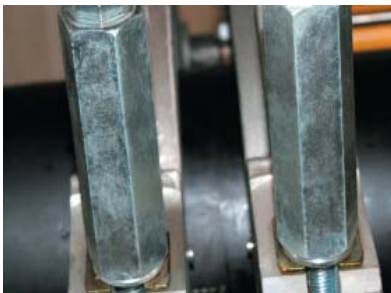

- If one pipe end is slightly higher than the other, lower it to the aligned position by tightening the hold-down clamp on that section of pipe. Do not loosen hold-down clamps to obtain alignment.
- If misalignment is side-to-side, slight rotation of the shorter section will help bring them into alignment.
- When joining coiled pipe, it may be necessary to rotate each end of pipe to make an "S" or "U" shape and re-clamp the pipe to provide acceptable alignment. Reface pipe ends.

If any of the above alignments are necessary, the facing operation must be repeated.

Bring pipe ends together, applying force equal to or greater than the fusion force to be used. Make sure the pipe does not slip.

When satisfactory alignment has been achieved, separate the clamp assemblies to make room for insertion of the heater.

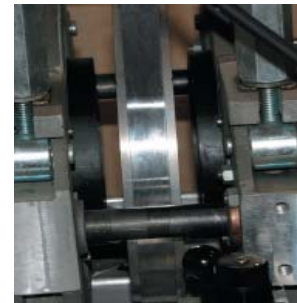

Fusing the Pipe

Recheck heater for proper temperature recommended by pipe manufacturer. Use surface pyrometer to check temperature of heater face surface. If pyrometer indicates that temperature is not as recommended, refer to instructions for setting temperature before proceeding

Wipe both faces of the heater body with heater face towel or a soft clean cotton cloth to remove any contaminants. Do not use polyester material to clean heater faces. Place the heater plate between the pipe ends.

NOTE: The heater is coated with a non-stick surface to minimize sticking and contamination of the molten plastic. This coating should be wiped clean before fusing each joint, using a clean, soft rag.

Set the hydraulic directional valve to the left (closed) position, and operate the pump to bring the pipe ends against the heater plate.

Force the pipe ends into the heating plate according to the pressure and time recommendations of the pipe manufacturer's fusion procedure.

Maintain pipe-to-heater contact for recommended length of time or size of melt bead specified by the pipe manufacturer. After a small bead has appeared and formed around the pipe, slowly move the directional valve to the neutral position to release the pressure to zero (0) psi. **DO NOT APPLY FORCE.**

Note: As pipe ends reach proper temperature, a melt bead will form where the pipe ends contact the heater. The "size of the bead" is often referred to by pipe manufacturers to determine if proper melt has been reached.

When heating is complete, set the hydraulic directional valve to the right (open) position, and operate the pump to separate the pipe ends from the heater plate.

Remove the heater plate quickly, being careful to avoid contact with the heated pipe ends.



Caution: Heater tool is extremely hot and will burn exposed skin and damage clothing.

Quickly inspect pipe ends to ensure melt is uniform. If melt is not uniform and does not meet pipe manufacturer's recommendations, replace the heater in its holder. The pipe must be refaced, repeating at the facing operation.

Note: The exact amount of pressure to apply during fusion is determined by following pipe manufacturer's recommended procedures. Check pipe manufacturer's literature to determine how the bead should appear.

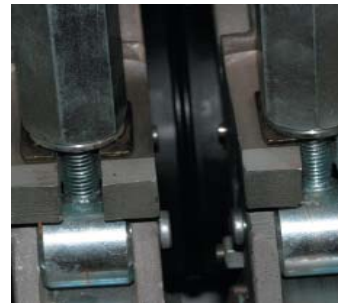

- Over-pressuring the fusion joint will cause the bead to be too large and could result in an inferior fusion. The melt can be pushed to the OD and out of the ID of the fusion bead, creating a possible "cold joint" in the center section of the fusion.
- Under-pressuring the fusion joint could result in an inferior fusion due to insufficient interfacial contact in the melt area.
- Extreme care should be exercised to maintain pressure during the fusion operation even if bead exceeds desired width. Reversing pressure can cause porosity in the fused area.



Caution: Let heater cool in atmosphere. Do not submerge into water for cooling. Internal components will be damaged.

Quickly set the hydraulic directional valve to the left (closed) position and operate the pump to bring the pipe ends together.

Force the pipe ends together according to the pressure and time (or type of bead) recommendations of the pipe manufacturer's fusion procedure.

When fusion is complete, set the directional valve to the neutral, or middle, position and loosen the hold down clamps.

Remove Pipe

Note: It is best not to test, stress, pull, or rough-handle newly fused pipe until the minimum cooling time specified by the manufacturer has been reached.

Open all hold down clamps. Remove the pipe from the unit.

Fusing of Valves/Elbows

Full bore valves or elbows can be fused to pipe with the 28LM with no modifications to the machine. Valves or elbows can be installed in either the movable or stationary clamp.

Maintenance

Guide Rods

Wipe clean daily to assure smooth travel of the carriage.

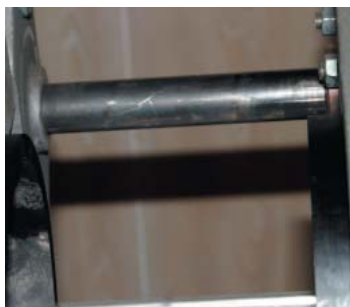

Hydraulic System

The system holds approximately .8 gallons of hydraulic fluid. Check the fluid daily and change the fluid after each 500 operating hours. Operation in an extremely dusty environment necessitates more frequent fluid changes.



To Bleed Air From the Hydraulic System
(Each Cylinder has two bleeder screws one on top at the front end and one on top at the rear end.)

- Elevate the front of the jig.
- Loosen the bleeder screws on the front of both cylinders.
- Set the directional valve to its closed position.
- Operate the pump until air bubbles are no longer present in the fluid coming from the bleeder screws.
- Tighten the bleeder screws.
- Elevate the rear end of the jig.
- Loosen the bleeder screws at the rear of both cylinders. Set the directional valve to its open position.
- Operate the pump until air bubbles are no longer present in the fluid coming from the bleeder screws.
- Tighten the bleeder screws.
- Repeat this bleed procedure as needed for smooth operation.

NOTE: Be sure to maintain oil level in the hydraulic reservoir.

Facer Assembly

Slow facing operation and rough pipe ends indicate dull blades. Replace dull blades.

The facer should be disassembled every three months and inspected. If needed, the bearing should be repacked with Mobil 28 grease or an equivalent.

Motor Brush Replacement – Check the motor brushes every 45 hours of operation. Replace brushes that are worn to less than 0.25 inches (0.64 cm). Install replacement brushes in the same position from which the worn brushes were removed. Clean out motor housing with compressed air every week and more frequently in an extremely dusty environment.



Heater Assembly

Read these instructions before performing any maintenance on the 28LM heater assembly. Only a qualified technician should perform tool repair to assure work is done in accordance with approved electrical standards.

Should the heater fail to heat properly, it must be returned to the factory for repairs.

Some causes of heater plate malfunction include:



- Improper power source.
- Extension cord(s) too long.
- Extension cord(s) of inadequate load size.
- Generator running too slowly.

RECOMMENDATION: For servicing and /or re-application of the non-stick coating, return the heater to Connectra Fusion Technologies, LLC.

Disassembly of Carriage Hydraulic Cylinder

Note: Before disassembly, make sure all power is disconnected and make sure the hydraulic system pressure is showing zero pressure.



Note: Cap or plug the hydraulic lines to reduce contamination from foreign materials.

- Remove the cylinder from the jig.
- Very gently remove the end cap.
- Remove the piston rod assembly.
- Assemble in reverse order.

Routine Maintenance

28LM heaters are normally set at 450°F at the factory. An information card accompanies the heater and specifies exactly what temperature is set.

The temperature can be adjusted with a screwdriver. Clockwise rotation lowers the temperature and counterclockwise rotation raises it. One complete revolution will adjust temperature about 100°F. Temperature should not be changed more than ¼ of a revolution at a time.

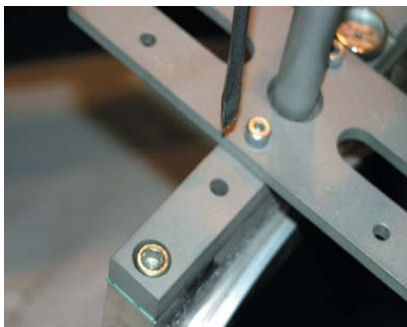

Should the heater plates become scratched or otherwise marred, remove them and return them to the factory for re-coating. Always disconnect power cord from power source before adjusting the temperature. This will eliminate the possibility of injury due to electric shock.

Keep the heater face clean with a cotton cloth. Do not use polyester material, it will stick to the surface.

Replacment/Accessory Parts

Facer Assembly - 120V	500310
Cart Assembly	101111
Heater Assembly - 120V	600266
Facer Blade Set	28-0208-4560-40
Heater Butt Plate Set	600260
Heater Bag	28-8208-3520-10
Heater Stand	600268
Thermoswitch	V00169
Heater Cartridge - 120V .5 X 6	V00025
Heater Cartridge - 120V .5 X 8	V00026
Thermometer	V00168
Stub End Holder	800030
Pipe Stands	800161
Hydraulic Extension Hose	800185
Hydraulic Cylinder Seal Kit	300431

CONNECTRA FUSION
BUTT FUSION GAUGE PRESSURES
28LM MACHINE--1.964 sq. in. CECA

IPS PIPE ONLY

IPS	IPS						SDR						
Nominal	Actual	7.0	7.3	9.0	9.3	11.0	11.5	13.5	15.5	17.0	21.0	26.0	32.5
2.000	2.375	83	80	67	65	56	54	46	41	37	31	25	20
3.000	3.500	180	174	145	141	121	117	101	89	81	67	54	44
4.000	4.500	297	287	240	233	201	193	167	147	134	110	90	72
5.000	5.375	424	410	342	332	286	275	238	209	192	157	128	103
5.000	5.563	454	439	366	356	307	295	255	224	205	168	137	111
6.000	6.625	644	622	520	505	435	418	361	318	291	239	195	157
7.000	7.125	745	720	601	584	503	483	418	367	337	276	225	182
8.000	8.625	1092	1055	881	856	737	708	612	538	494	405	330	266

Interfacial Pressure 75

Combined Effective Cylinder Area 1.964

You must also add drag pressure. This is the hydraulic pressure required to move the carriage while holding the pipe, and is easily overlooked. If two long pieces of pipe are being fused, the drag factor can reach several hundred pounds.

This data is provided as a guide only and is believed to be accurate and reliable. However, the user should always use the recommendations and procedures of the pipe manufacturer and/or the owner of the pipeline. Due to the variability of applications and service conditions, no warranty, expressed or implied, is given in conjunction with the use of this data.

CONNECTRA FUSION
BUTT FUSION GAUGE PRESSURES
28LM MACHINE--1.964 sq. in. CECA

DIPS PIPE ONLY

DIPS	DIPS						SDR						
Nominal	Actual	7.0	7.3	9.0	9.3	11.0	11.5	13.5	15.5	17.0	21.0	26.0	32.5
4.000	4.800	338	327	273	265	228	219	189	167	153	125	102	82
6.000	6.900	699	675	564	548	472	453	392	345	316	259	211	170
8.000	9.050	1203	1161	970	942	812	780	674	593	544	445	363	293

Interfacial Pressure 75

Combined Effective Cylinder Area 1.964

You must also add drag pressure. This is the hydraulic pressure required to move the carriage while holding the pipe, and is easily overlooked. If two long pieces of pipe are being fused, the drag factor can reach several hundred pounds.

This data is provided as a guide only and is believed to be accurate and reliable. However, the user should always use the recommendations and procedures of the pipe manufacturer and/or the owner of the pipeline. Due to the variability of applications and service conditions, no warranty, expressed or implied, is given in conjunction with the use of this data.

CONNECTRA FUSION
BUTT FUSION GAUGE PRESSURES
28LM MACHINE--1.964 sq. in. CECA

DIPS PIPE ONLY

DIPS	DIPS						SDR						
Nominal	Actual	7.0	7.3	9.0	9.3	11.0	11.5	13.5	15.5	17.0	21.0	26.0	32.5
4.000	4.800	271	261	218	212	183	175	152	133	122	100	82	66
6.000	6.900	559	540	451	438	377	363	313	276	253	207	169	136
8.000	9.050	962	929	776	754	649	624	539	474	435	356	291	234

Interfacial Pressure 60

Combined Effective Cylinder Area 1.964

You must also add drag pressure. This is the hydraulic pressure required to move the carriage while holding the pipe, and is easily overlooked. If two long pieces of pipe are being fused, the drag factor can reach several hundred pounds.

This data is provided as a guide only and is believed to be accurate and reliable. However, the user should always use the recommendations and procedures of the pipe manufacturer and/or the owner of the pipeline. Due to the variability of applications and service conditions, no warranty, expressed or implied, is given in conjunction with the use of this data.

Statement of Warranty

Warranty/Disclaimers – Connectra Fusion Technologies, LLC (“Seller”) warrants for a period of three (3) years from the date of invoice that the products sold under the order invoiced (the “Products”) will be free from defects in materials and workmanship, except for items supplied to Seller by other vendors in connection with the order. The items to which the warranty does not extend (the “Excluded Items”) include, without limitation, electrical devices, pumps, controls, and similar items. Seller assigns to the buyer of the Products, without recourse, any warranty on the Excluded Items which is provided by manufacturer thereof.

The warranty provided hereby does not apply to any product or component that has been repaired or altered by anyone other than Seller, and does not cover any failure of the Products which Seller determines to have been caused due to abuse, misuse, negligence or normal wear and tear.

As a condition to the buyer's exercise of its rights under this warranty, the Products must be returned to Seller's dock, freight prepaid, in Gainesville, Texas, within ten (15) days of the date of failure, accompanied by a Return Goods Authorization (available from Seller) and information related to the claim. Buyer's REMEDIES UNDER THIS WARRANTY ARE LIMITED to, at Seller's sole option, the replacement or repair of the Products determined by Seller to be defective, or a refund of the purchase price, less an allowance for services rendered by the Product prior to the warranty claim. IN NO EVENT SHALL SELLER BE LIABLE FOR LOSS OF USE, DAMAGE TO OR LOSS OF PRODUCTS OR SERVICES, FAILURE TO REALIZE EXPECTED SAVINGS, FRUSTRATION OF ECONOMIC OR BUSINESS EXPECTATIONS, LOST REVENUE OR PROFITS, OR FOR ANY OTHER SPECIAL, INCIDENTAL, CONSEQUENTIAL OR PUNITIVE DAMAGES, EVEN IF THEY WERE FORESEEABLE OR SELLER WAS INFORMED OF THEIR POTENTIAL. Products repaired or replaced pursuant to this warranty will be delivered to buyer FOB Seller's dock in Gainesville, Texas.

THIS WARRANTY IS IN LIEU OF ALL OTHER WARRANTIES EXPRESS OR IMPLIED, INCLUDING THE WARRANTIES OF MERCHANTABILITY AND

FITNESS FOR PARTICULAR PURPOSE, WHICH ARE EXPRESSLY DISCLAIMED. SELLER NEITHER ASSUMES NOR AUTHORIZES ANY OTHER PERSON TO MODIFY THESE TERMS AND CONDITIONS, WARRANT SPECIFIC APPLICATIONS, OR ASSUME FOR SELLER ANY OTHER LIABILITY IN CONNECTION WITH THE SALE OF ANY SELLER'S PRODUCT OTHER THAN AS PROVIDED IN THIS WARRANTY.

Recommendations - Any recommendations and suggestions provided by Seller concerning its products and the use thereof are based on tests and data believed to be reliable but are not intended to be complete or exhaustive. The user is responsible for determining the applicability of governmental regulations relating to the use of the products and for all other aspects of the use of Seller's products.

Actual use of the products by others is beyond the control of Seller and Seller makes no warranty or other agreement, expressed or implied, regarding any aspect of such use. Seller shall have no liability arising from the use of Seller's products by a third party.

Modifications – Seller may improve or otherwise modify its products without any obligation to improve or otherwise modify in any way any products (including any parts or accessories) previously sold by Seller.

Distributors – Seller's products are sold through authorized distributors, who determine the price, terms and conditions of sale.

Other – No partial invalidity of this agreement shall affect the remainder. This agreement shall be governed and construed in accordance with the laws of Texas, excluding its laws relating to conflicts-of-law.

The sole purpose of the exclusive remedy contained in the limited Warranty shall be to provide repair or replacement of failed products, or to refund the purchase price of the failed product as explained above. This exclusive remedy shall not be deemed to have failed of its essential purpose so long as Seller agrees to repair or replace the failed product or to refund the purchase price as explained above.

